

# FMB630 Accessories

[Main Page](#) > [EOL Products](#) > [FMB630](#) > [FMB630 Manual](#) > **FMB630 Accessories**

✘ Please order accessories separately as they are not included into device package.

## Fuel tank sensors

A fuel tank level sensor which indicates the approximate fuel level on the driver's indicator panel exists in most cars. If the sensor returns analogue signal proportional to fuel level it can be connected to FMB630 Analog input. After connection to the tank fuel level sensor a calibration is needed because most fuel tank sensors are not linear. Calibration is performed by measuring voltage values resulting from the volume of fuel in tank.

## Alarm buttons, door sensors etc.

Alarm buttons, door sensors, ignition, etc. have two output states: high or low. FMB630 Digital inputs are used to detect these states.

## Relays

In cases when sensor output signal is negative, an additional relay has to be installed to convert negative signal to positive.

## Immobilizer relay

When connected as shown on the right hand side, FMB630 disables engine starter when output is ON.

## Fuel sensor connection to FMB630

✘

## Panic button connection to FMB630

✘

## Inverting relay connection to FMB630

✘

## Immobilizer relay connection to FMB630 output

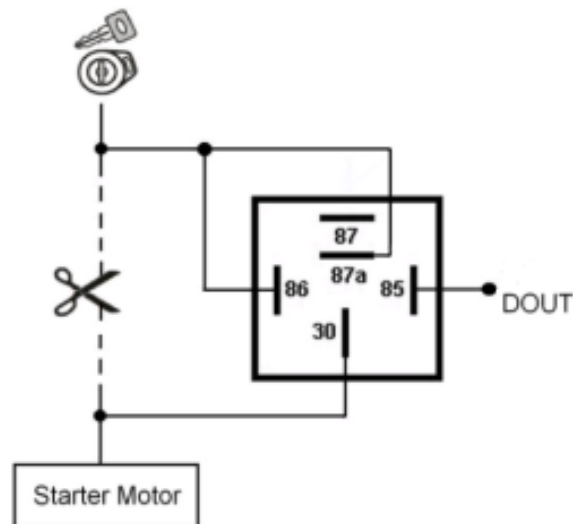

## Automotive relay

An ordinary automotive relay is used to invert input signal or to immobilize engine starter. Note that relays can be 12 V or 24 V capable.

✘

## 1-Wire devices

## Automotive relay pinout

✘

## Digital thermometer DS1820 and TTJ100 connection to FMB630

One of the implemented features on FMB630 is 1-Wire® data protocol, which enables connection to devices such as thermometer (DS1820, DS18S20 and DS18B20) and I-Button DS1990A.



TTJ sensor pinout



**I-Button DS1990A connection to FMB630**



**Pulse fuel meters connection scheme**

### **Impulse counters**

Here two pulse meters are used, where one is mounted on the direct flow valve and the other on the return flow valve. Data from both meters is sent to the FMB630. Then FMB630 calculates DIN3-DIN4. Resulting difference equals to fuel consumption. Filter should be used on the direct flow pipe to prevent any damage caused by impurities in the liquid. The filter mounted in the meter inlet is only a safety filter and it is too small to act as a strainer. Read more about impulse counters [here](#)

