

FMC880 General description

[Main Page](#) > [Fast & Easy Trackers](#) > [FMC880](#) > [FMC880 Manual](#) > **FMC880 General description**

FMC880 is a tracking terminal with GNSS,GSM and LTE CAT 1 connectivity, which is able to collect device coordinates and transfer them via GSM/LTE CAT 1 network to the server. This device is perfectly suitable for applications, which need location acquirement of remote objects.

□

Contents

- [1 Package contents](#)
- [2 Basic characteristics](#)
- [3 Technical features](#)
- [4 Technical information about internal battery](#)
- [5 Electrical characteristics](#)
- [6 Absolute maximum ratings](#)

Package contents

The FMC880 device is supplied to the customer in a cardboard box containing all the equipment that is necessary for operation. The package contains:

- FMC880 device;
- Top and bottom device cover parts;

Basic characteristics

GSM / GPRS / GNSS features:

- FMC880-QJAB0: Quectel EG915U-EU with AG3335;
- Technology LTE CAT 1/GSM/GPRS/GNSS/BLUETOOTH;
- SMS (text, data);
- Integrated GNSS receiver;
- Up to -165 dBm GNSS receiver sensitivity.

CELLULAR:

Technology	Supported bands
2G bands	FMC880-QJAB0: GSM: B2/B3/B5/B8 850/900/1800/1900 FMC880-QKABO: GSM: B2/B3/B5/B8 850/900/1800/1900
4G bands	FMC880-QJAB0: LTE FDD: B1/B3/B7/B8/B20/B28 FMC880-QKABO: LTE FDD: B2/B3/B4/B5/B7/B8/B28/B66
Data transfer (Quectel)	LTE: LTE FDD: Max 10Mbps (DL)/Max 5Mbps (UL) GSM: GPRS: Max 85.6Kbps (DL)/Max 85.6Kbps (UL)

Hardware features:

- Built-in movement sensor;
- Built-in Bluetooth 4.0;
- Internal High Gain GNSS antenna;
- Internal High Gain GSM antenna;
- 128MB internal flash memory;
- 170 mAh Li-ion rechargeable 3.7 V battery.

Interface features:

- Power supply: 10 ÷ 30 V;
- USB port;
- 2 LEDs indicating device status.

Special features:

- Fast position fix;
- High Quality track even in high density urban canyon;
- Small case;
- High gain internal GNSS and GSM antennas;
- 2 LED status indication;
- Real-time tracking;
- Smart data acquisition based on:
 - Time;
 - Angle;
 - Distance;
 - Ignition or any other I/O event.
- Sending acquired data via GPRS;
- GPRS and SMS I/O events;
- Virtual odometer;
- Jamming detection;
- Configurable using Secured SMS Commands;
- Spy call;
- Overvoltage protection.

Description	Voltage	Duration
Normal operation	+10 ... +30 V	Unlimited
Protection turns on, device turns off	34 V	Unlimited
Maximum voltage	<70 V	Unlimited
Maximum voltage impulse	90 V	5 ms

Technical features

Part name	Physical specification
Navigation indication	LED

Modem indication	LED
USB	Micro USB socket
GNSS	Internal GNSS antenna
GSM	Internal GSM antenna

Technical details

2 W max. Current consumption at 12 V (Power supply 10...30 V DC)	GPRS: average 37 mA Nominal: average 24.41 mA GNSS sleep: average 11.2 mA Deep Sleep: average 5.1 mA Online Deep Sleep: average 9.6 mA Ultra Deep Sleep: average 2.4 mA
Battery charge current	Average 120 mA
Rated current	250 mA
Operating temperature (without battery)	-40..+85 °C
Storage temperature (without battery)	-40..+85 °C
Storage relative humidity	5..95% (no condensation)
Internal fuse	3A, 125V
Power Cable + Device + case + battery weight	80 g

Dimension drawing (tolerance $\pm 2\text{mm}$):

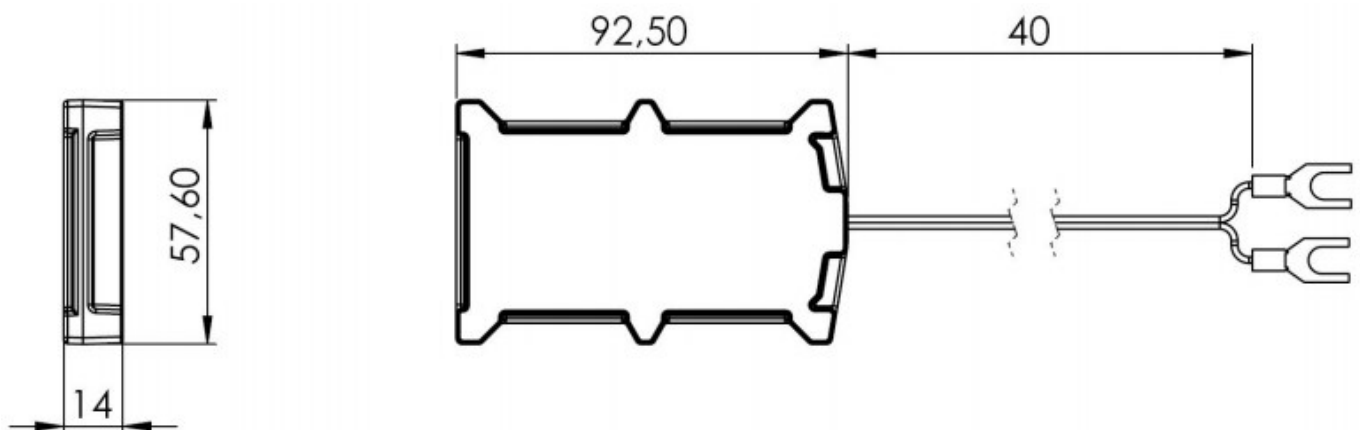

Technical information about internal battery

Internal back-up battery	Battery voltage (V)	Nominal capacity (mAh)	Power (Wh)	Charge temperature (°C)	Discharge temperature (°C)	Storage temperature (°C)
Li-ion rechargeable battery	3.75□3.90	170	0.64 - 0.66	0 to +45	-20 to +60	-20 to +45 for 1 month -20 to +35 for 6 months

Batteries are covered by 6 month [warranty](#) support.

- ✘ CAUTION: RISK OF EXPLOSION IF BATTERY IS REPLACED BY AN INCORRECT TYPE. DISPOSE OF USED BATTERIES ACCORDING TO THE INSTRUCTIONS.
Battery should not be disposed of into general household waste.
- ✘ Bring damaged or worn-out batteries to your local recycling center or dispose them into a battery recycle bin commonly found in supermarkets.

Electrical characteristics

Characteristic description	Value			Unit
	Min.	Typ.	Max.	
Supply Voltage:				
Supply Voltage (Recommended Operating Conditions)	+10		+30	V
Input voltage (Recommended Operating Conditions)	0		Supply voltage	V

Absolute maximum ratings

Characteristic description	Value			Unit
	Min.	Typ.	Max.	
Supply Voltage (Absolute Maximum Ratings)	-32		+32	V