

# MTB100 General description

[Main Page](#) > [EOL Products](#) > [MTB100](#) > [MTB100 Manual](#) > **MTB100 General description**

MTB100 is a tracking terminal with GNSS and GSM connectivity, which is able to collect device coordinates and transfer them via GSM network to a server. This device is perfectly suitable for applications, which require the location acquirement of remote objects.

□

## Contents

- [1 Package contents](#)
- [2 Basic characteristics](#)
- [3 Technical features](#)
- [4 Technical information about internal battery](#)
- [5 Electrical characteristics](#)
- [6 Absolute maximum ratings](#)

## Package contents

The MTB100 device is supplied to the customer in a cardboard box containing all the equipment that is necessary for operation. The package contains:

- Already implemented MTB100 device into case;
- Top and bottom device cover parts;
- 3.7 V 170 mAh rechargeable Li-ion battery;
- and output power supply cable with a 1x5 connection pins, which is already installed into device.

## Basic characteristics

GSM / GPRS / GNSS features:

- Teltonika [TM2500](#) quad band module (GSM 850 / 900 / 1800 / 1900 MHz);
- GPRS class 12 (Up to 85,6 kbps);
- SMS (text, data);
- Integrated GNSS receiver;
- Up to -165 dBm GNSS receiver sensitivity.

Hardware features:

- Built-in movement sensor;
- Built-in Bluetooth 3.0;
- Built-in Bluetooth 4.0;
- Internal High Gain GNSS antenna;
- Internal High Gain GSM antenna;

- 128 MB Flash (422 400 Records);
- 170 mAh Li-ion rechargeable 3.7 V battery.

#### Interface features:

- Power supply: +6... +30 V;
- 1 digital input;
- 1 analog input;
- 1 open collector digital output (connecting external relays, LED, buzzers etc);
- 1 LED indicating device status.

#### Special features:

- Fast position fix;
- High Quality track even in high density urban canyon;
- Ultra small case;
- Ready for harsh environment;
- Easy to mount in limited access areas;
- Firmly fasten;
- 1 LED status indication;
- Real time tracking;
- Smart data acquisition based on:
  - Time;
  - Speed;
  - Angle;
  - Distance;
  - Ignition or any other I/O event;
- Sending acquired data via GPRS;
- GPRS and SMS I/O events;
- Virtual odometer;
- Jamming detection;
- Configurable using Secured SMS Commands;

<b>Description</b>	<b>Voltage</b>	<b>Duration</b>
Normal operation	+6 ... +30 V	Unlimited

## Technical features

<b>Part name</b>	<b>Physical specification</b>
Status LED	LED
Socket	Soldered inner socket
USB	Micro USB socket

## Technical details

2 W max.	GPRS: average 63.48 mA
Current consumption at 12 V (Power supply 6...30 V DC)	Nominal: average 24.40 mA
	GNSS sleep: average 4.78 mA
	Deep Sleep: average 3.65 mA
	Online Deep Sleep: average 4.10 mA
	Ultra Deep Sleep: average 2.56 mA
Battery charge current	Average: 140 mA
	Rated: 250 mA
Operating temperature (without battery)	-40 ... +85 °C
Storage temperature (without battery)	-40 ... +85 °C
Storage relative humidity	5 ... 95% (no condensation)
Device + case weight + battery weight	54 g

Dimension drawing:

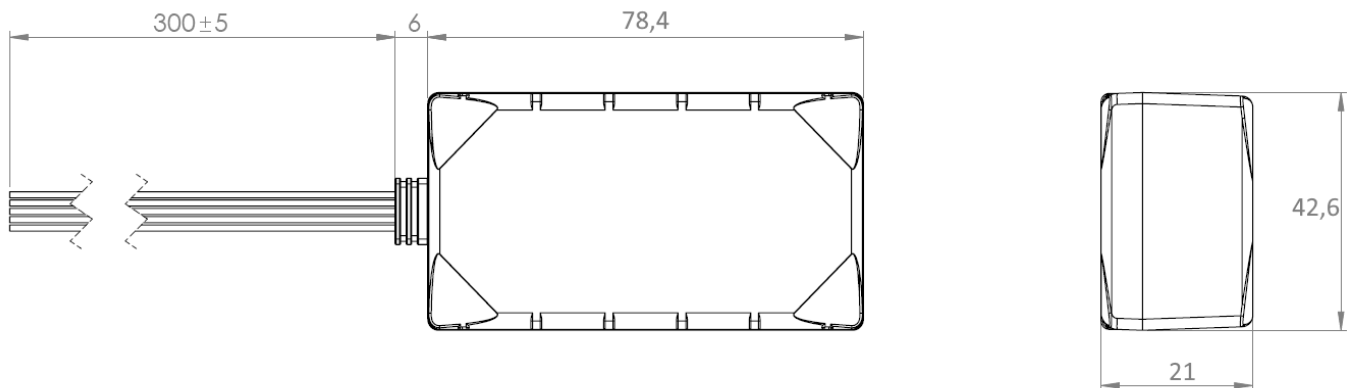

## Technical information about internal battery

Internal back-up battery	Battery voltage (V)	Nominal Capacity (mAh)	Power (Wh)	Charge temperature (°C)	Discharge temperature (°C)	Storage temperature (°C)
Li-ion rechargeable battery	3.75□3.90	170	0.64 - 0.66	0 to +45	-20 to +60	-20 to +45 for 1 month -20 to +35 for 6 months

Batteries are covered by 6 month [warranty](#) support.

 CAUTION: RISK OF EXPLOSION IF BATTERY IS REPLACED BY AN INCORRECT TYPE. DISPOSE OF USED BATTERIES ACCORDING TO THE INSTRUCTIONS.

Battery should not be disposed of into general household waste.

- ✘ Bring damaged or worn-out batteries to your local recycling center or dispose them into a battery recycle bin commonly found in supermarkets.

## Electrical characteristics

Characteristic description	Value			Unit
	Min.	Typ.	Max.	
Supply Voltage:				
Supply Voltage (Recommended Operating Conditions)	6		30	V
Digital Output (Open Drain grade):				
Drain current (Digital Output OFF)			120	µA
Drain current (Digital Output ON, Recommended Operating Conditions)	0.1		0.5	mA
Static Drain-Source resistance (Digital Output ON)			300	mΩ
Digital Input:				
Input resistance (DIN1)	47			kΩ
Input voltage (Recommended Operating Conditions)	0		Supply voltage	V
Input Voltage threshold (DIN1)		2.5		V
Analog Input:				
Input voltage (Recommended Operating Conditions)	0		30	V
Input resistance		150		kΩ
Measurement error on 12 V		3		%
Additional error on 12 V		360		mV
Measurement error on 30 V		3		%
Additional error on 30 V		900		mV

- ✘ Analog Input error margin can increase if temperature varies.

## Absolute maximum ratings

Characteristic description	Value			Unit
	Min.	Typ.	Max.	
Supply Voltage (Absolute Maximum Ratings)	-32		+32	V
Drain-Source clamp threshold voltage (Absolute Maximum Ratings), ( $I_{\text{drain}} = 2 \text{ mA}$ )			+36	V
Digital Input Voltage (Absolute Maximum Ratings)	-32		+32	V

Analog Input Voltage  
(Absolute Maximum Ratings)

-32

+32 V